

UWELL CALIBURN

User Manual

UWELL CALIBURN G4 Pod System

©2025 By SHENZHEN UWELL TECHNOLOGY CO., LTD.
All Rights Reserved.

Illustration

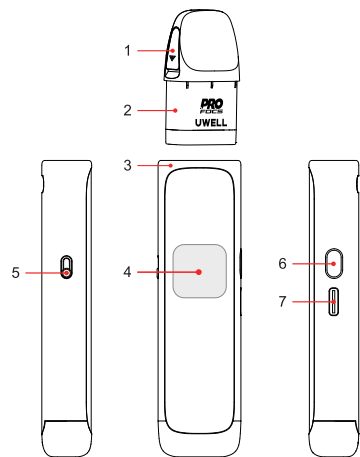

1. Filler plug
2. Cartridge
3. Device
4. Screen
5. Airflow adjustment valve
6. Button
7. TYPE-C charging port

Specifications

Materials	PC	Aluminum alloy	ADC12	PCTG
Dimensions	Length: 114.98mm	Width: 26mm	Thickness: 15.65mm	
Cartridge Specifications	3ML	0.4 Ω / 0.6 Ω / 0.9 Ω		
Net Weight	54.7 g			
Output Power	Maximum 35 W			
Battery Capacity	1300 mAh			

Quick Guide

1. Take the cartridge off the device, then remove the insulating film from the bottom.
2. Fill e-liquid into the filling port, and then wait for 10 minutes after its first filling.
3. Insert the cartridge into the device, press the button 5 times in 2 seconds to turn on the pod system, then draw to vape or press the button to vape.

Instructions

1. Cartridge Filling and Replacement

- a. Take the cartridge off the new device for the first filling and remove the insulating film on the bottom of the cartridge before use.
- b. Open the filler plug and fill the cartridge with e-liquid.
- c. Put the filler plug back after filling.
- d. Insert the cartridge back into the device.
- e. For the cartridge replacement, please remove the used cartridge and insert a new one.

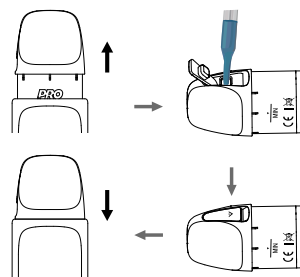

Attention:

- a. Insert the nozzle of the e-liquid bottle into the filling port to fill it with e-liquid.
- b. Please put the filler plug back as soon as the filling is done, and make sure it is properly sealed to prevent e-liquid leakage.
- c. Let the cartridge sit for 10 minutes after the first filling to avoid coil burning.
- d. Please make a timely refilling when the e-liquid is under the MIN level.

2. Airflow Adjustment

Insert the cartridge into the device and adjust the airflow with the airflow adjustment valve.

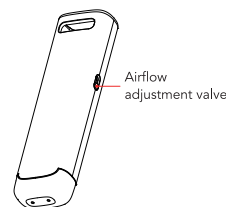

3. Turn On/Off

Press the button 5 times within 2 seconds to turn on/off the device. The screen will show "CALIBURN" when turning on and show "UWELL" when turning off.



4. Standby

The screen will be off in 10 seconds if without any operation, and the device will be in standby.

5. Menu Setting

a. **Mode Choosing:** Press the button 4 times to enter the menu setting interface, choose from the "THEME"、"MODE"、"DAY"、"NIGHT" or "PUFF" mode, and long press to confirm, then the screen will return to the main user interface.



b. **Theme Choosing:** Long press the "THEME" button to enter the menu of theme setting interface. Choose the preferred theme, and long press to confirm, then the screen will return to the main user interface. If there's no operation within 3s, the system will choose the current theme automatically.



c. **Mode Choosing:** On the menu interface, press to choose "MODE" and long press to enter the mode selection menu. Press to switch between "WAVES" and "STORM" and long press to confirm the choosing. After that, the system will back to the main user interface. If there's no operation within 3s on the mode choosing interface, the system will choose the current mode automatically.



d. **Brightness Choosing:** On the menu interface, press to choose "DAY" or "NIGHT" and long press to confirm the choosing. After confirmation, the system will back to the main user interface with the currently chosen brightness.

e. **Puff Record Resetting:** Press the "PUFF" button on the menu interface and long press to confirm the puff record. After resetting the puff record, the screen will return to the main user interface.



f. **Menu Exiting:** 1. Long press the "EXIT" button on the menu to exit this interface; 2. The screen will go back to the main user interface in 3 seconds if without any operation.

6. Ignition Mode Switching

1. When turning on the device for the first time, the device will enter the auto mode by default, which supports both air activation and button activation.

2. Press the button twice in 2 seconds to switch to air activation mode and lock the button ignition function.



3. Press the button twice in 2 seconds to switch to the auto mode and unlock the button ignition function.



7. Vaping

Please take a draw or press the button to vape when the device is turned on.

8. Puff Record

a. The device will only record puffs that last over 0.3 seconds. The puffs that last less than 0.3 seconds will not be counted. The maximum number of records is 99,999; the recorded numbers will be reset to 1 automatically when exceeding 99,999.

9. Power Adjustment

- a. Press the button 3 times in 2 seconds to enter into power adjustment mode. The output power wattage will flash on the screen during adjusting.
- b. Press or long press the button to choose a preferred power among the corresponding power range.
- c. Wait for 3 seconds or take a draw to confirm the power setting, then the output power wattage will stop flashing on the screen and exit the power adjustment mode.

Cartridge Resistance	Power Range
0.4 Ω	5 W - 35 W
0.6 Ω	5 W - 25 W
0.9 Ω	5 W - 15 W
1.2 Ω	5 W - 11 W



10. Battery Level Indication

The screen will indicate the percentage of battery level in real-time.

11. Charging

When connecting the device to a power source through a TYPE-C charging cable, the screen will show the charging animation. When it stops charging, the screen will go back to the main user interface.



12. Protection and Indication

a. **Short-circuit protection:** When a short-circuit occurs, the screen displays "Atomizer short!" and the device stops outputting.



b. **Low voltage protection:** When the power is low, the screen displays "Battery Low!" and the device stops outputting.



c. **Overtime protection:** The screen displays "Over 8s!" to indicate an over 8-second vaping, and the device stops outputting.



d. **Open-circuit protection:** When an open-circuit occurs under a no cartridge or disconnection situation, the screen displays "No Atomizer" and the device stops outputting.



Warm Tips

1. Please charge with the certified power adaptor (5V/2A) and USB cable.
2. Please remove the cartridge from the device and store it separately when you travel by air, for the air pressure change may cause leakage.
3. Avoid high temperature, low temperature, flammables, explosives, water, and humid environment during the use or storage of the product. Please do not keep the product with hard objects to avoid damage. Please charge the device at least once a month.

WARNING

The new FDA regulations apply to the sales and distribution of all E-cig products.

1. Do not give away free samples.
2. It is prohibited to sell all types of E-cig products to people under the age of 21.
3. It is prohibited to sell all types of E-cig products in vending machines except those specified by laws and regulations.
4. It is prohibited to introduce products with "light", "low", "mild", or other similar descriptions in labels or advertisements into interstate trade.
5. It is strictly forbidden to be used by young children, pregnant women, and women during breastfeeding or patients with heart disease, hypertension, diabetes, depression, and asthma. Keep the product out of the reach of children, non-smokers, and animals.
6. Please do not drink it.
7. It may contain nicotine, which is known to be a highly addictive substance.
8. Swallowing or skin contact with this product may cause intoxication.
9. Please keep away from flammables and explosives when using or charging to avoid hazards.
10. Do not disassemble the product. The company won't be responsible for any product damage or personal injury caused by the improper operation.
11. Please consult your local vape shop or contact us through service@myuwell.com if you need help using the product.

Product Verification

- Visit UWELL's official website www.myuwell.com to verify under the SUPPORT navigation bar.
- Please scan the QR code on the package with your phone camera to verify. The result will be displayed on the page.
- Or you can enter the 16-bit anti-counterfeit code on the surface of the user manual into the input box, and the result will be displayed within seconds.

Attention:

Please keep your package and the warranty card.

Warranty Period

180 days from the purchasing date.

Warranty Parts

Device and atomizer only. Coil and pod are excluded.

Warranty Service Excluded Conditions

1. Expiration of warranty period.
2. Damage caused by failure to use, maintain and keep the product according to the requirements of the product instructions.
3. Damage caused by maintenance service personnel non-authorized by UWELL.
4. Damage caused by using inferior accessories of other brands.
5. Damage caused by the force majeure.

Warranty Service Guide

1. You can ask the shop you purchased your vaping device for the warranty service.
2. You can visit www.myuwell.com and ask for warranty service under the SUPPORT navigation bar.
3. You can contact us through service@myuwell.com if you have any questions.



Please use your phone camera to scan the QR code for further information.